

Total Tankless Solution (TTS) Specification Sheet

TTS-S2MINI

Standard Commercial Tankless Water Heater System

UNMATCHED TECHNOLOGY

FRG's TTS-S2MINI Series provides the most complete commercial water heater solution in the market. This tankless water heating system provides up to 399,800 BTU/hr in the smallest footprint while having the advantage of redundancy and equalizing heating performance.

KEY FEATURES

OPC (One Point of Connection)

- Water, Recirculation Return Line, Power, Gas, Venting & Condensation Drain

Manifold systems

- Hot Water Outlet, Cold Water Inlet, Gas, Condensate Drain

Building recirculation

Reduction in labor hours

Worry-free installation

Designed to fit through 3'-0" x 7'-0" Door

Pre-engineered system

Pre-configured control wiring

Pre-installed system controllers

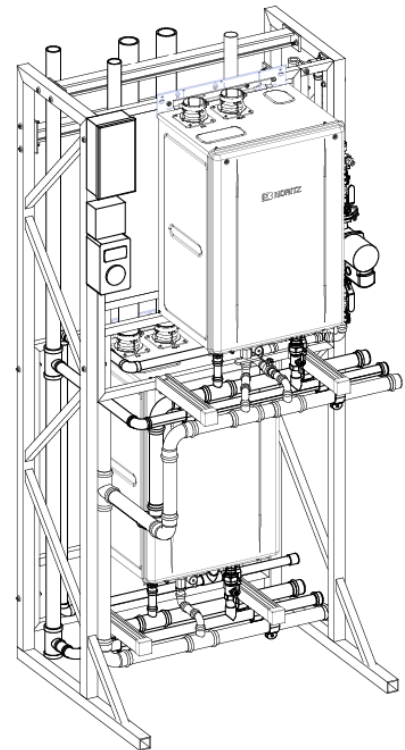

Warranty

- 10 Years Heat Exchanger per Tankless Unit
- 5 Years Water Heater Parts & Components
- 3 Year Circulation Pump
- 1 Year Labor

Additional Included Accessories:

- Condensate Neutralizer (Qty 1)
- Expansion Tank (Non-ASME)
- 4.5 Gallon (TTS-S2MINI/3/4MINI Models)

TTS-S SERIES SPECIFICATIONS (SYSTEM DIMENSIONS)

Model: TTS-S2MINI

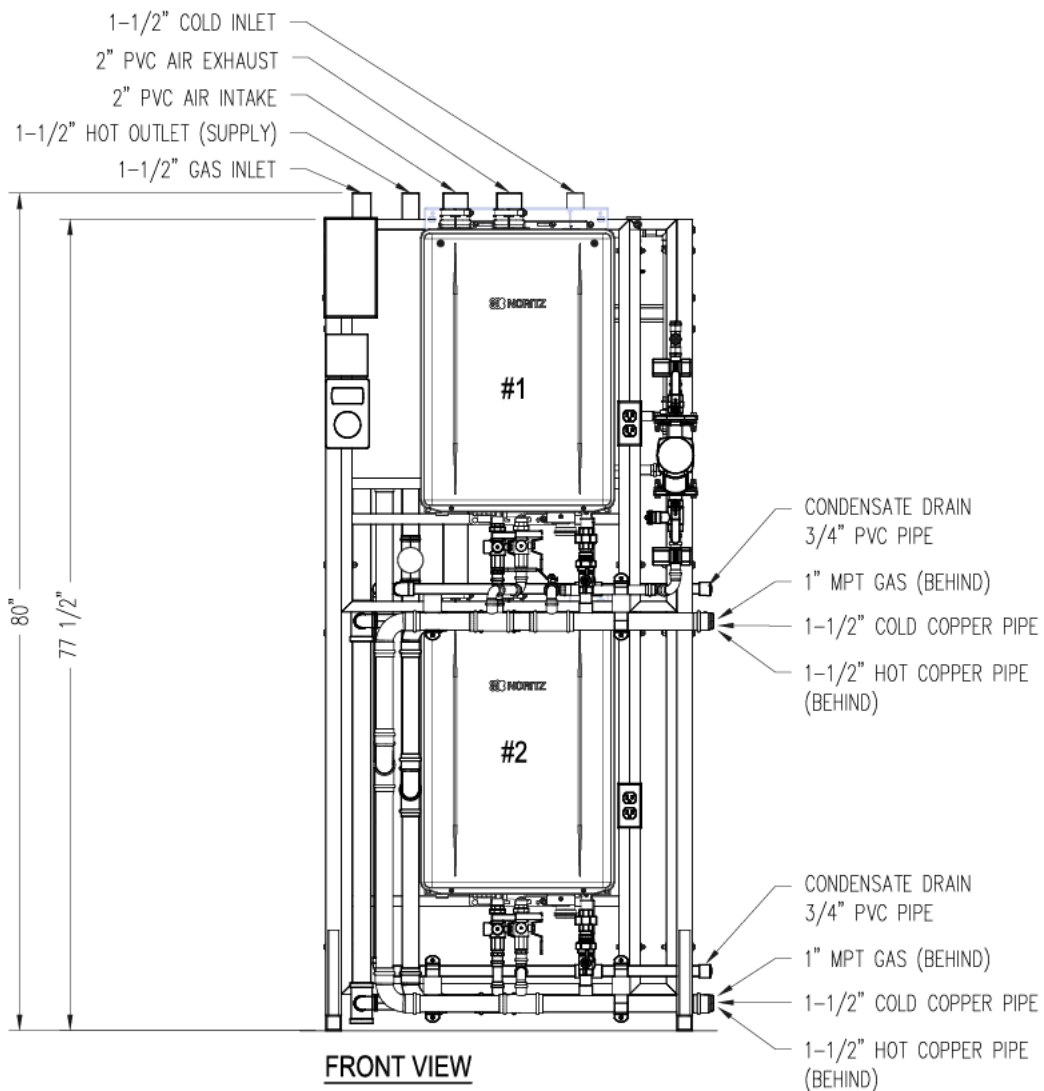
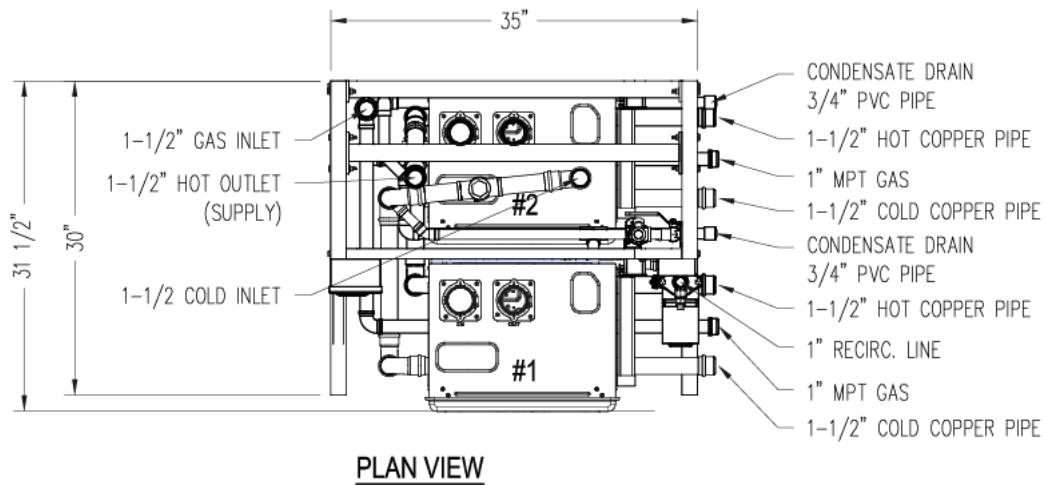

TTS-S SERIES SPECIFICATIONS (PARAMETERS)

Model Name		TTS-S2MINI
Min. Input (BTU/HR)		18,000
Max. Output (BTU/HR)		399,800
Turn Down Ratio		22:1
System Dimensions L X D X H (IN)		35 X 31.5 X 80 (51 CU. FT.)
System Weight (LBS)		180
Shipping Dimensions L X D X H (IN)		45.5 X 42 X 83.5 (92 CU. FT.)
Shipping Weight (LBS)		360
GPH @100°F Rise		468
Operating Pressure		15 - 150 psi
Gas Supply Pressure		NG: 3.5" - 10.5" LP: 8.0" - 14.0"
Water Holding Capacity		0.80 Gallon (3.2L) per Heater
Connection Size	Water Inlet	1-1/2" LC-ODT/PP
	Hot Water Outlet	1-1/2" LC-ODT/PP
	Hot Water Recirculation Return	3/4" LC-ODT/PP
	Gas Inlet	1-1/2" Sch40-BI-NPT
	Condensate Drain	3/4" Sch 40 PVC-ODT
Power Consumption	Supply Total Rack	208/240 VAC 1-PH 20-AMPS
	Sub - Heater	120VAC (60Hz), less than 4 amperes
	Sub - Recirculation Pump	120VAC (60Hz), 5 to 45W
Temperature Setting	°F Mode	100-150°F (In 5°F intervals), 160°F, 170°F, 185°F (14 Options)
	°C Mode	37-48°C (In 1°C intervals), 50-85°C (In 5°C intervals) (20 Options)
Materials	Heater Front Cover	Hot-dipped zinc-aluminum-magnesium-alloy-coated steel w/ Polyester Coating
	Heater Casing	Zincified Steel Plate / Polyester Coating
	System Rack	Aluminum
Pump Performance	Sub - Recirculation Pump	3.5-GPM @ 15' of head (see Pump Curve below)

