

### Total Tankless Solution (TTS) Specification Sheet

# TTS-S3

## Standard Commercial Tankless Water Heater System

### UNMATCHED TECHNOLOGY

FRG's TTS-S3 Series provides the most complete commercial water heater solution in the market. This tankless water heating system provides up to 599,700 BTU/hr in the smallest footprint while having the advantage of redundancy and equalizing heating performance.

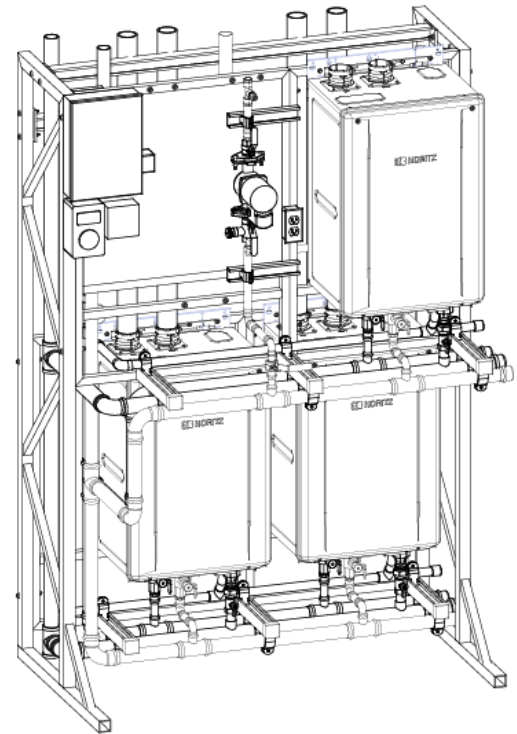

### KEY FEATURES

#### OPC (One Point of Connection)

- Water, Recirculation Return Line, Power, Gas, Venting & Condensation Drain

#### Manifold systems

- Hot Water Outlet, Cold Water Inlet, Gas, Condensate Drain

#### Building recirculation

#### Reduction in labor hours

#### Worry-free installation

#### Designed to fit through 3'-0" x 7'-0" Door

#### Pre-engineered system

#### Pre-configured control wiring

#### Pre-installed system controllers

#### Warranty

- 10 Years Heat Exchanger per Tankless Unit
- 5 Years Water Heater Parts & Components
- 3 Year Circulation Pump
- 1 Year Labor

#### Additional Included Accessories:

- Condensate Neutralizer (Qty 1)
- Expansion Tank (Non-ASME)  
- 4.5 Gallon (TTS-S2MINI/3/4MINI Models)

# TTS-S SERIES SPECIFICATIONS (SYSTEM DIMENSIONS)

## Model: TTS-S3

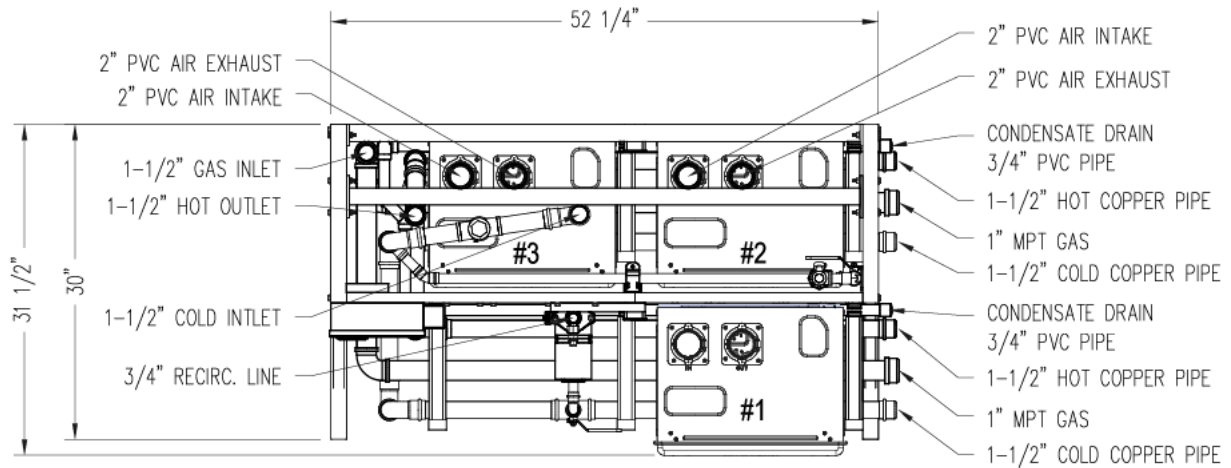

**PLAN VIEW**

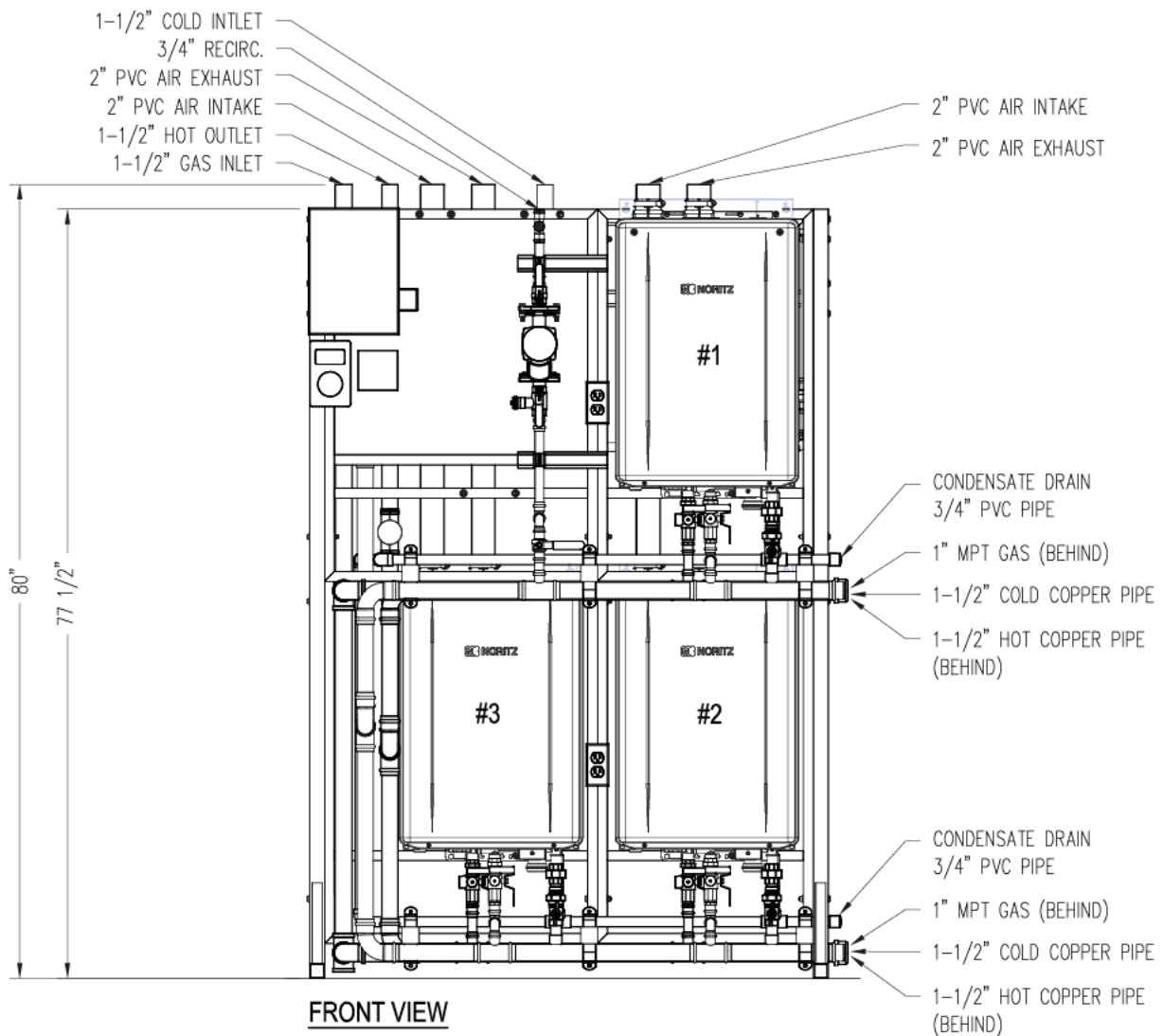

**FRONT VIEW**

# TTS-S SERIES SPECIFICATIONS (PARAMETERS)

<b>Model Name</b>		<b>TTS-S3</b>
<b>Min. Input (BTU/HR)</b>		18,000
<b>Max. Output (BTU/HR)</b>		599,700
<b>Turn Down Ratio</b>		33:1
<b>System Dimensions L X D X H (IN)</b>		52.25 X 31.5 X 80 (76 CU. FT.)
<b>System Weight (LBS)</b>		295
<b>Shipping Dimensions L X D X H (IN)</b>		65.5 X 42 X 83.5 (133 CU. FT.)
<b>Shipping Weight (LBS)</b>		525
<b>GPH @100°F Rise</b>		702
<b>Operating Pressure</b>		15 - 150 psi
<b>Gas Supply Pressure</b>		NG: 3.5" - 10.5" LP: 8.0" - 14.0"
<b>Water Holding Capacity</b>		0.80 Gallon (3.2L) per Heater
<b>Connection Size</b>	Water Inlet	1-1/2" LC-ODT/PP
	Hot Water Outlet	1-1/2" LC-ODT/PP
	Hot Water Recirculation Return	3/4" LC-ODT/PP
	Gas Inlet	1-1/2" Sch40-BI-NPT
	Condensate Drain	3/4" Sch 40 PVC-ODT
<b>Power Consumption</b>	Supply Total Rack	208/240 VAC 1-PH 20-AMPS
	Sub - Heater	120VAC (60Hz), less than 4 amperes
	Sub - Recirculation Pump	120VAC (60Hz), 5 to 45W
<b>Temperature Setting</b>	°F Mode	100-150°F (In 5°F intervals), 160°F, 170°F, 185°F (14 Options)
	°C Mode	37-48°C (In 1°C intervals), 50-85°C (In 5°C intervals) (20 Options)
<b>Materials</b>	Heater Front Cover	Hot-dipped zinc-aluminum-magnesium-alloy-coated steel w/ Polyester Coating
	Heater Casing	Zincified Steel Plate / Polyester Coating
	System Rack	Aluminum
<b>Pump Performance</b>	Sub - Recirculation Pump	3.5-GPM @ 15' of head (see Pump Curve below)

