

### Total Tankless Solution (TTS) Specification Sheet

# TTS-TWST2

## Tankless With Storage Tank Commercial Tankless Water Heater System

### UNMATCHED TECHNOLOGY

FRG's TTS-TWST2 Series provides the most complete commercial water heater solution in the market. This tankless water heating system provides up to 399,800 BTU/hr in the smallest footprint while having the advantage of redundancy and equalizing heating performance.

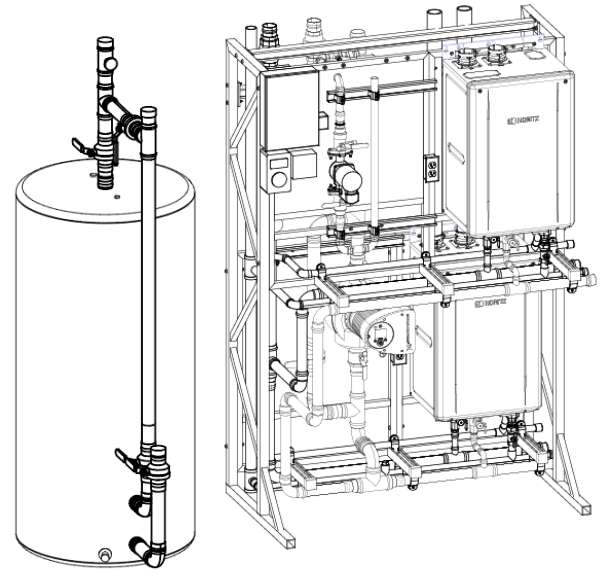

### KEY FEATURES

#### OPC (One Point of Connection)

- Water, Recirculation Return Line, Power, Gas, Venting & Condensation Drain

#### Manifold systems

- Hot Water Outlet, Cold Water Inlet, Gas, Condensate Drain

#### Building recirculation

#### Reduction in labor hours

#### System recirculation

#### Designed to fit through 3'-0" x 7'-0" Door

#### Pre-engineered system

#### Pre-configured control wiring

#### Pre-installed system controllers

#### Warranty

- 10 Years Heat Exchanger per Tankless Unit
- 5 Years Water Heater Parts & Components
- 3 Year Circulation Pump
- 1 Year Labor

#### Additional Included Accessories:

- Condensate Neutralizer (Qty 1)
- 115 Gallon Storage Tank with Manifolds
- Expansion Tank (Non-ASME)
- 20 Gallon (TTS-TWST2/3/4/5/6 Models)

# TTS-TWST SERIES SPECIFICATIONS (SYSTEM DIMENSIONS)

## Model: TTS-TWST2

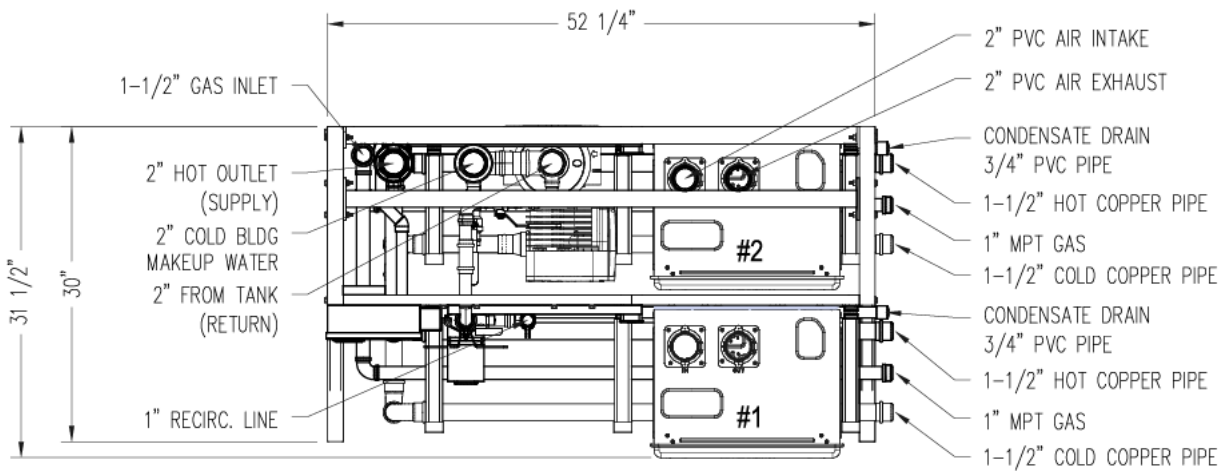

**PLAN VIEW**

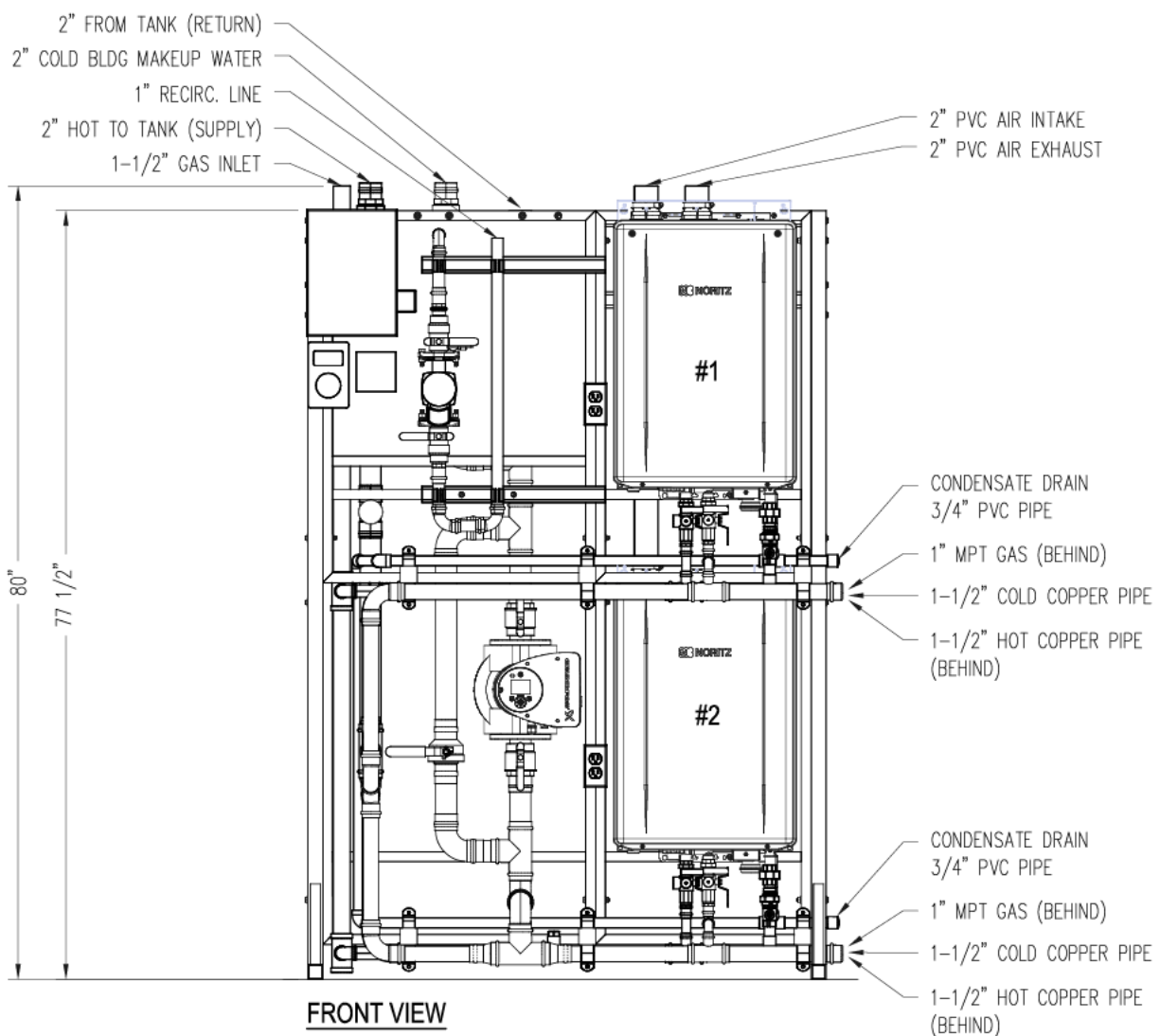

**FRONT VIEW**

# TTS-TWST SERIES SPECIFICATIONS (TANK DIMENSIONS)

Model: TTS-TWST2

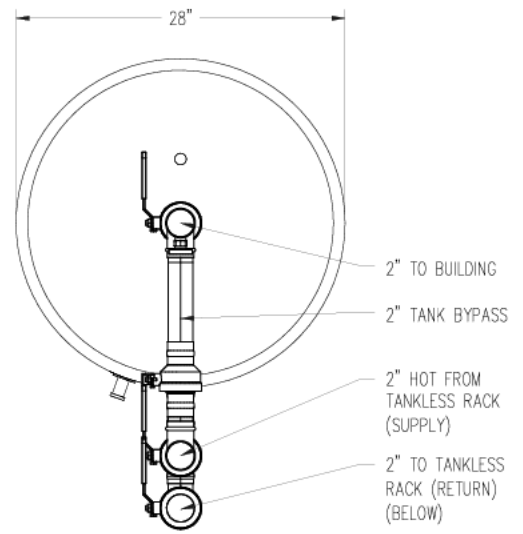

**PLAN VIEW**

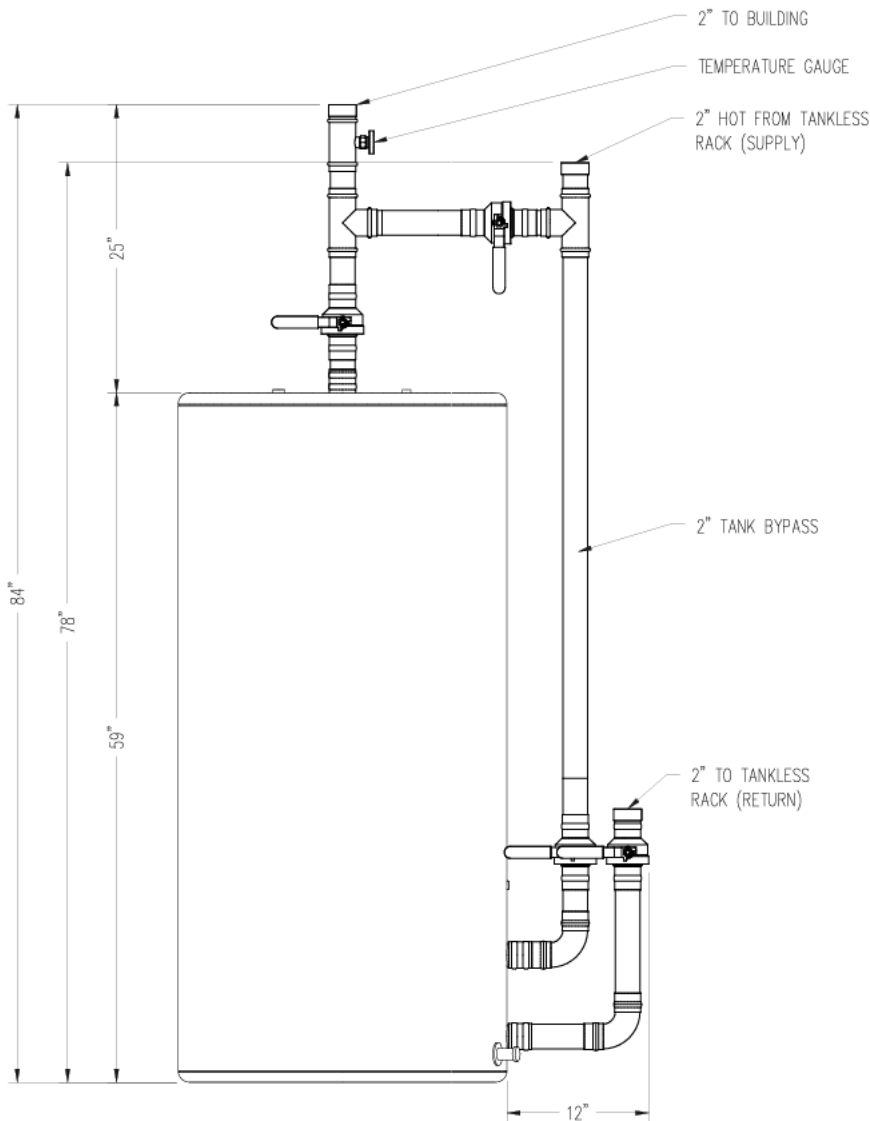

**LEFT SIDE VIEW**

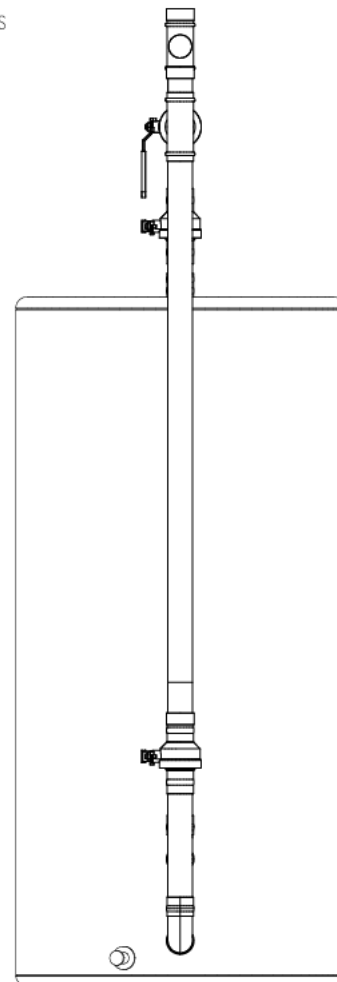

**FRONT VIEW**

## TTS-TWST SERIES SPECIFICATIONS (PARAMETERS)

Model Name		TTS-TWST2
Min. Input (BTU/HR)		18,000
Max. Output (BTU/HR)		399,800
Turn Down Ratio		22:1
System Dimensions L X D X H (IN)		87.25 X 31.5 X 104 (165 CU. FT.)
System Weight (LBS)		550
Shipping Dimensions L X D X H (IN)		92.25 X 38.5 X 107 (220 CU. FT.)
Shipping Weight (LBS)		740
GPH @100°F Rise		587.0
Operating Pressure		15 - 150 psi
Gas Supply Pressure		NG: 3.5" - 10.5" LP: 8.0" - 14.0"
Water Holding Capacity		0.80 Gallon (3.2L) per Heater
Storage Tank Water Holding Capacity		115 Gallon (435L)
Connection Size	Water Inlet	2" LC-ODT/PP
	Hot Water Outlet	2" LC-ODT/PP
	Hot Water Recirculation Return	1" LC-ODT/PP
	Gas Inlet	1-1/2" Sch40-BI-NPT
	Condensate Drain	3/4" Sch 40 PVC-ODT
Power Consumption	Supply Total Rack	208/240 VAC 1-PH 20-AMPS
	Sub - Heater	120VAC (60Hz), less than 4 amperes
	Sub - Recirculation Pump	120VAC (60Hz), 5 to 45W
	Sub - System Circulation Pump	120VAC (60Hz), 32 to 1196W
Temperature Setting	°F Mode	100-150°F (In 5°F intervals), 160°F, 170°F, 185°F (14 Options)
	°C Mode	37-48°C (In 1°C intervals), 50-85°C (In 5°C intervals) (20 Options)
Materials	Heater Front Cover	Hot-dipped zinc-aluminum-magnesium-alloy-coated steel w/ Polyester Coating
	Heater Casing	Zincified Steel Plate / Polyester Coating
	System Rack	Aluminum
Pump Performance	System Pump	Max 12-GPM @ 22' of head
	Sub - Recirculation Pump	3.5-GPM @ 15' of head (see Pump Curve below)

